

Industrial Engineering 416

Design Project



Instructor: Dr. Brett A. Peters
(adapted from Dr. A. Garcia-Diaz's material)

Problem Definition



Your team is going to design the *best facility* to satisfy the production requirements for your product(s).

Sample Facility (Block Layout)

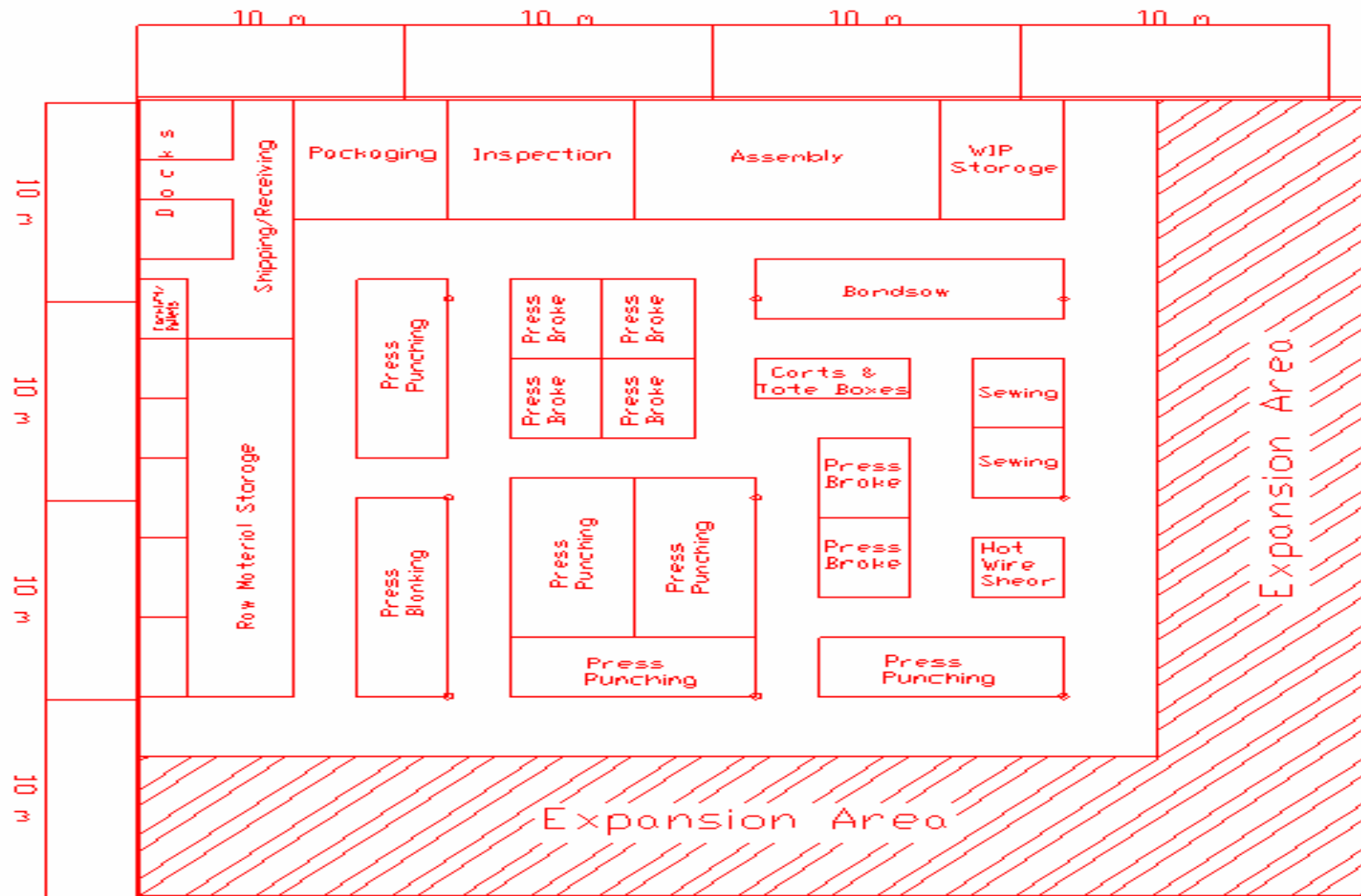

DESIGN PROCESS

- **Section I** - Product Analysis
- **Section II** - Manufacturing Planning
- **Section III** - Personnel Planning
- **Section IV** - Office Layout Design
- **Section V** - Plant Layout Planning/Analysis
- **Section VI** - Plant Layout Design

Section I ..

1.1 Product Selection



...Section I..

1.2 Parts List

- Summary of all parts needed for an assembly
- Purchased and manufactured parts
- Quantity needed and special remarks

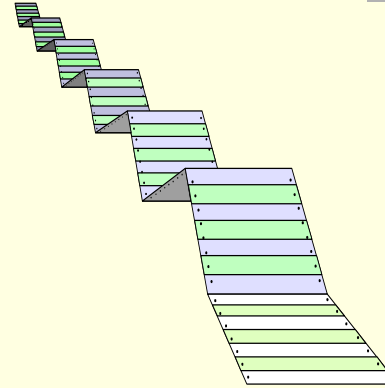

1.3 Part Drawings

- What is to be produced?
- Type of operations required



...Section I..

1.4 Assembly Drawings

- Relationship of individual parts in final assembly

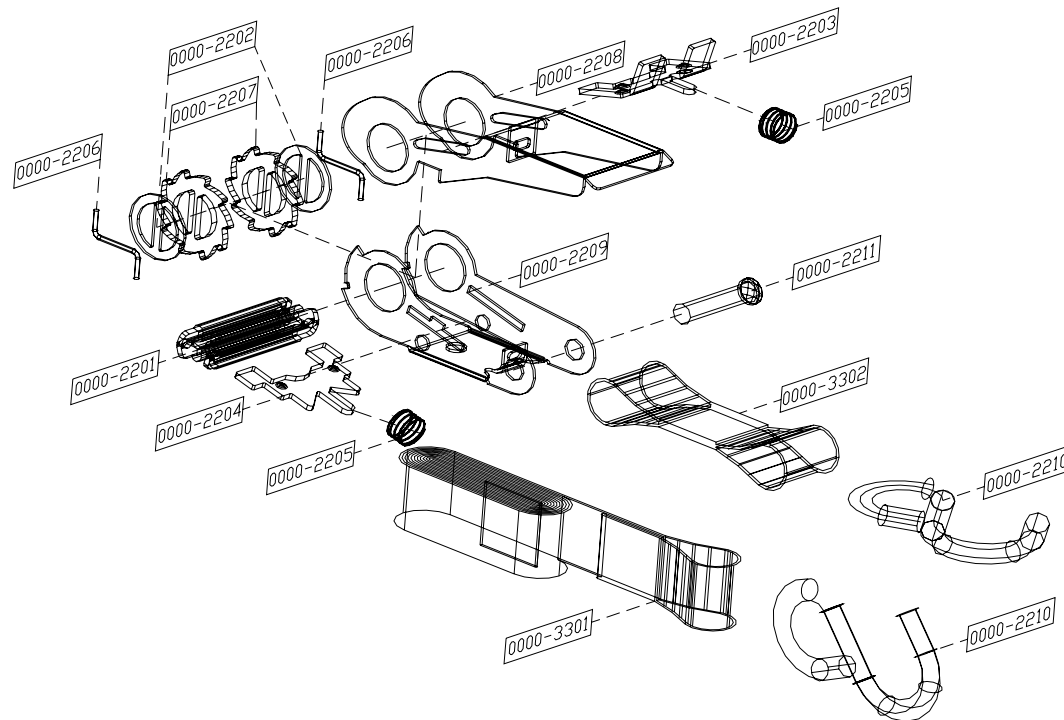

...Section I

1.5 Assembly Flow Chart

- Graphic representation of how to assemble the entire product by dividing into Sub-assemblies & Major assemblies
- Location of inspection stations

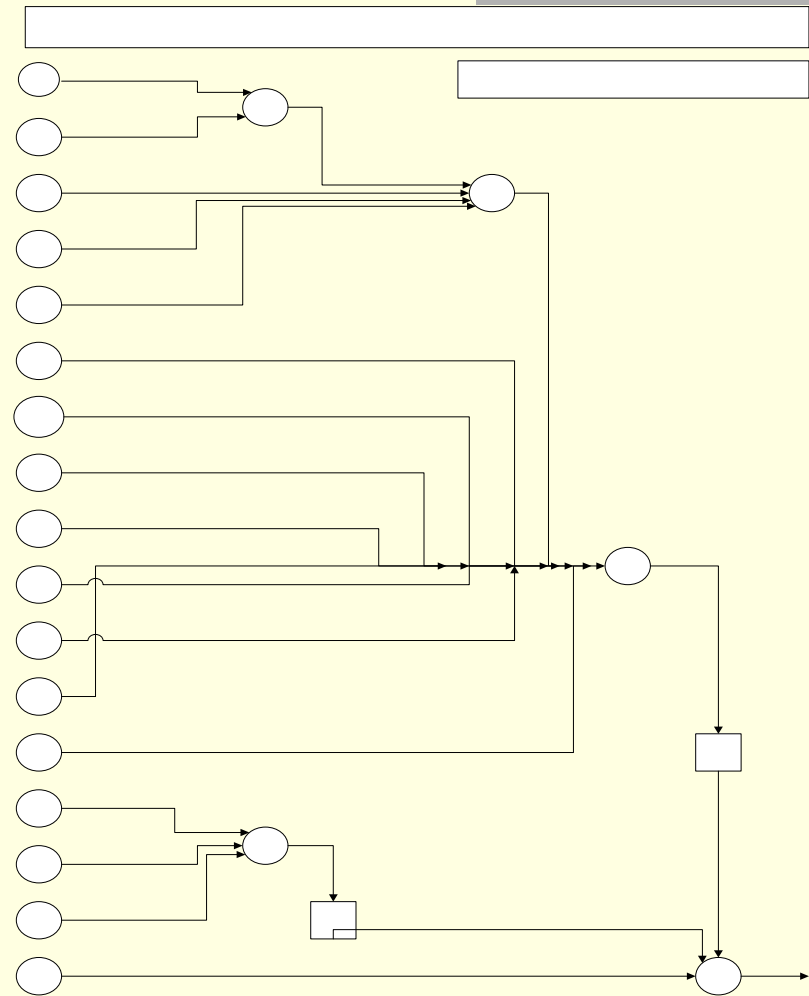

Section II...

2.1 Production Plan

2.2 Production Route Sheets

- Show sequential operations for a specific part, Machine type, Associated tools
- Helpful to determine machine and materials requirements and costs

...Section II...

- **2.3 Machine Requirements and Costs Table**
 - Types of machines
 - Brands
 - Models
 - Space required
 - Total annual machine costs

Machine Types

- Vinyl injection molder
- Punch press
- Compression molder
- Rubber injection molder
- Vulcanizing oven
- Drill press
- Lathe
- ...

...Section II

2.4 Material Requirements and Costs Table

- Amount considering scrap (weight basis)
- Material cost also based on weight
- Material scrap ranges from 5% to 70%
- Recycling



Section III

3.1 Manpower Calculations (direct and indirect-inspectors etc.)

3.2 Personnel Requirements and Costs

Categories

- Personnel positions
- Personnel required in each position
- Pay rate and annual salary for each position



Section IV...

Office Layout

- Designed to provide the executives and support personnel a work area which would be functional and pleasant to work in.

4.1 Personnel relationship chart

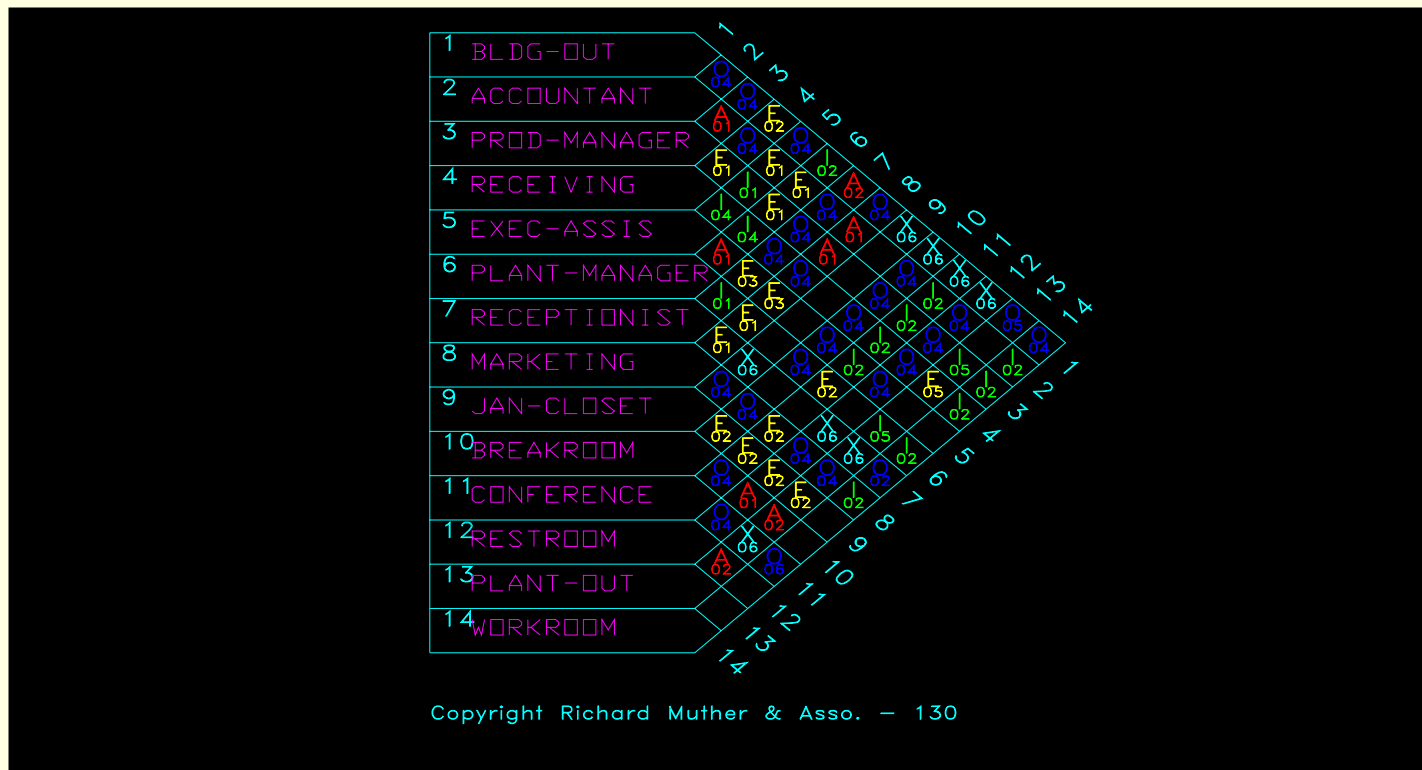

...Section IV...

4.2 FactoryOPT block layout

4.3 Detailed office layout

4.4 Layout evaluations and selection

...Section IV...

Ex: Office block layout

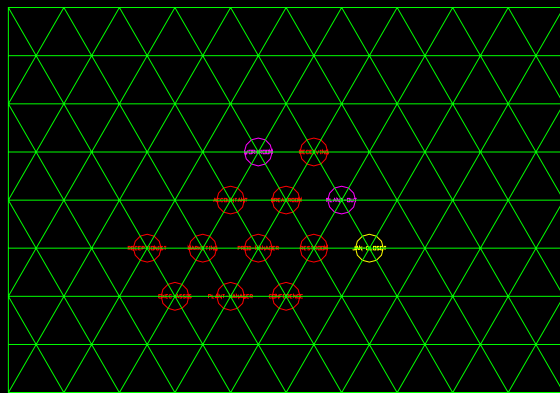

Layout -A

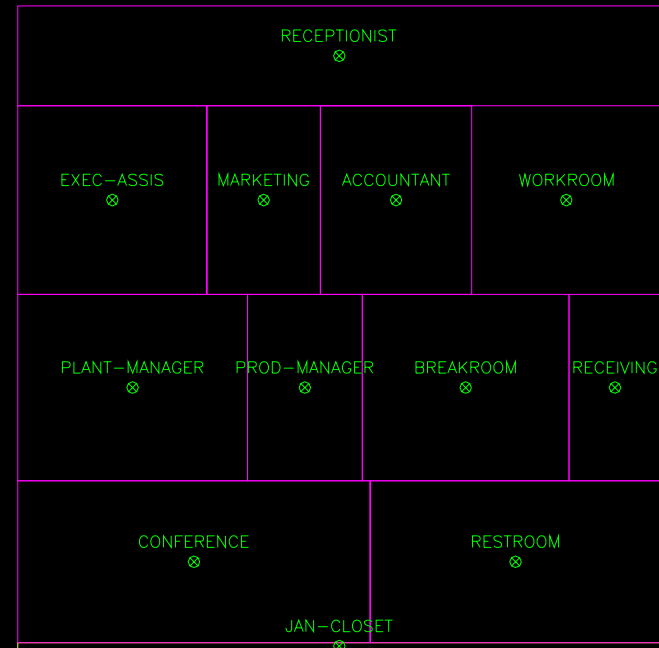

...Section IV

Ex: Detailed layout

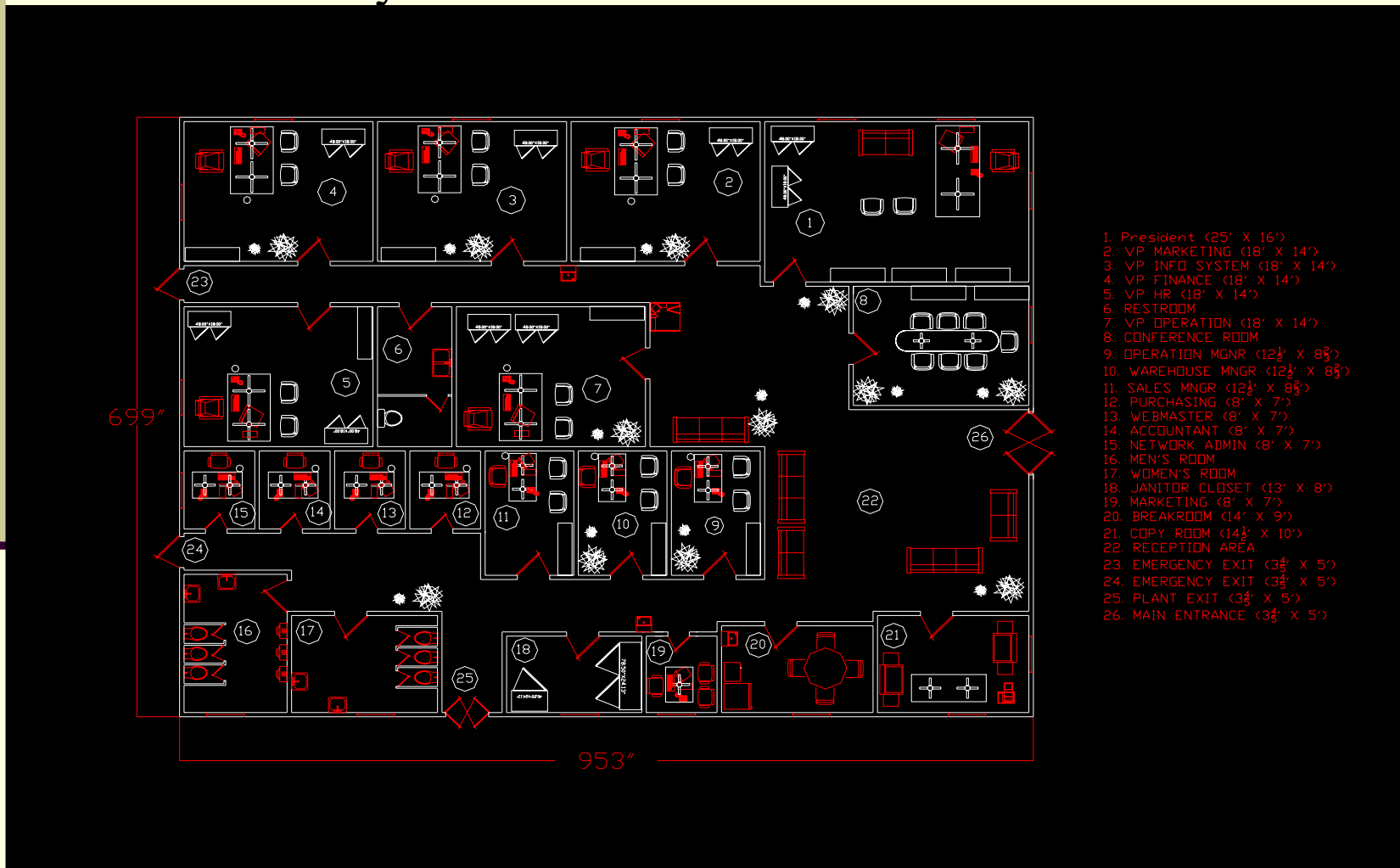

Section V...

Plant Layout

- Optimizes material flow.
- Facilitates efficient material handling.
- Designed for safe operation.

...Section V...

5.1 Preliminary workstation design

5.2 Material flow matrix

Flow Matrix

FROM	TO											
	D 1	D 2	D 3	D 4	D 5	D 6	D 7	D 8	D 9	D 10	D 11	D 12
D 1	0	17.5275	0	0	0	0	0	0	0	0	0	0
D 2	0	0	3.4275	0	0.4	8.5	4.1	1	0	0	0	0.2
D 3	0	0	0	68.55	0	0	0	0	0	0	0	0
D 4	0	0	0	0	56.74	0	0	0	0	0	0	11.81
D 5	0	0	0	0	0	0	20	0	0	0	0	36.74
D 6	0	0	0	0	0	0	8.4	0	0	0	0	0
D 7	0	0	0	0	0	0	0	0	0	20	0	20
D 8	0	0	0	0	0	0	0	0	0	0	0	1
D 9	0	0	0	0	0	0	0	0	0	40	0	0
D 10	0	0	0	0	0	0	0	0	0	0	60	0
D 11	2.604	0	0	0	0	0	0	0	0	0	0	0
D 12	0	0	0	0	0	0	0	0	89.95	0	0	0

Cost Matrix

FROM	TO											
	D 1	D 2	D 3	D 4	D 5	D 6	D 7	D 8	D 9	D 10	D 11	D 12
D 1	-	1.00000	0	0	0	0	0	0	0	0	0	0
D 2	0	-	0.19555	0	0.02282	0.48495	0.23392	0.05705	0	0	0	0.01141
D 3	0	0	-	0.07429	0	0	0	0	0	0	0	0
D 4	0	0	0	-	0.06149	0	0	0	0	0	0	0.01280
D 5	0	0	0	0	-	0	0.02168	0	0	0	0	0.03982
D 6	0	0	0	0	0	-	0.00910	0	0	0	0	0
D 7	0	0	0	0	0	0	-	0	0	0.02168	0	0.02168
D 8	0	0	0	0	0	0	0	-	0	0	0	0.00108
D 9	0	0	0	0	0	0	0	0	-	0.04335	0	0
D 10	0	0	0	0	0	0	0	0	0	-	0.06503	0
D 11	0.14857	0	0	0	0	0	0	0	0	0	-	0
D 12	0	0	0	0	0	0	0	0	0.09749	0	0	-

5.3 Department relationship chart

...Section V...

5.4 Material handling alternatives

- Manual handling
- Bench carts
- Flat truck
- Pallets
- Shipping dolly
- Storage racks
- ...

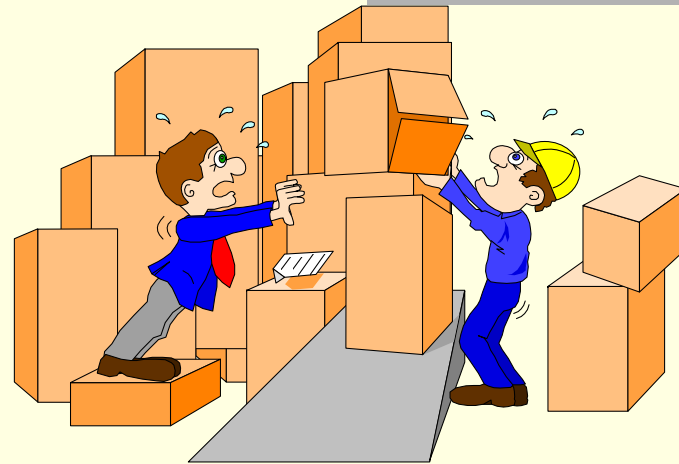

5.5 Material handling costs

- Shipping and handling charges
- Installation fees
- Associated costs

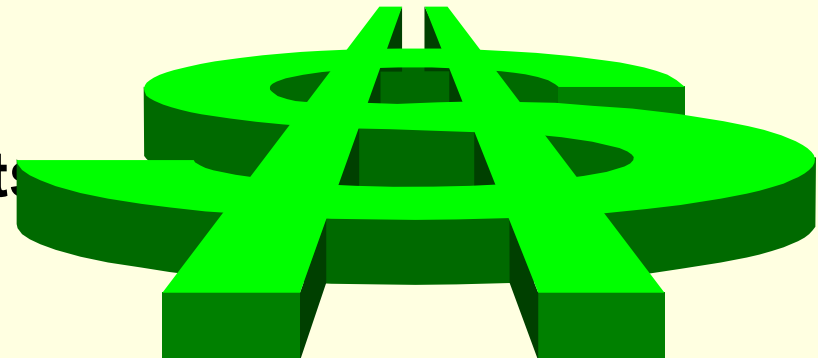

Section v (Systematic Layout Planning)

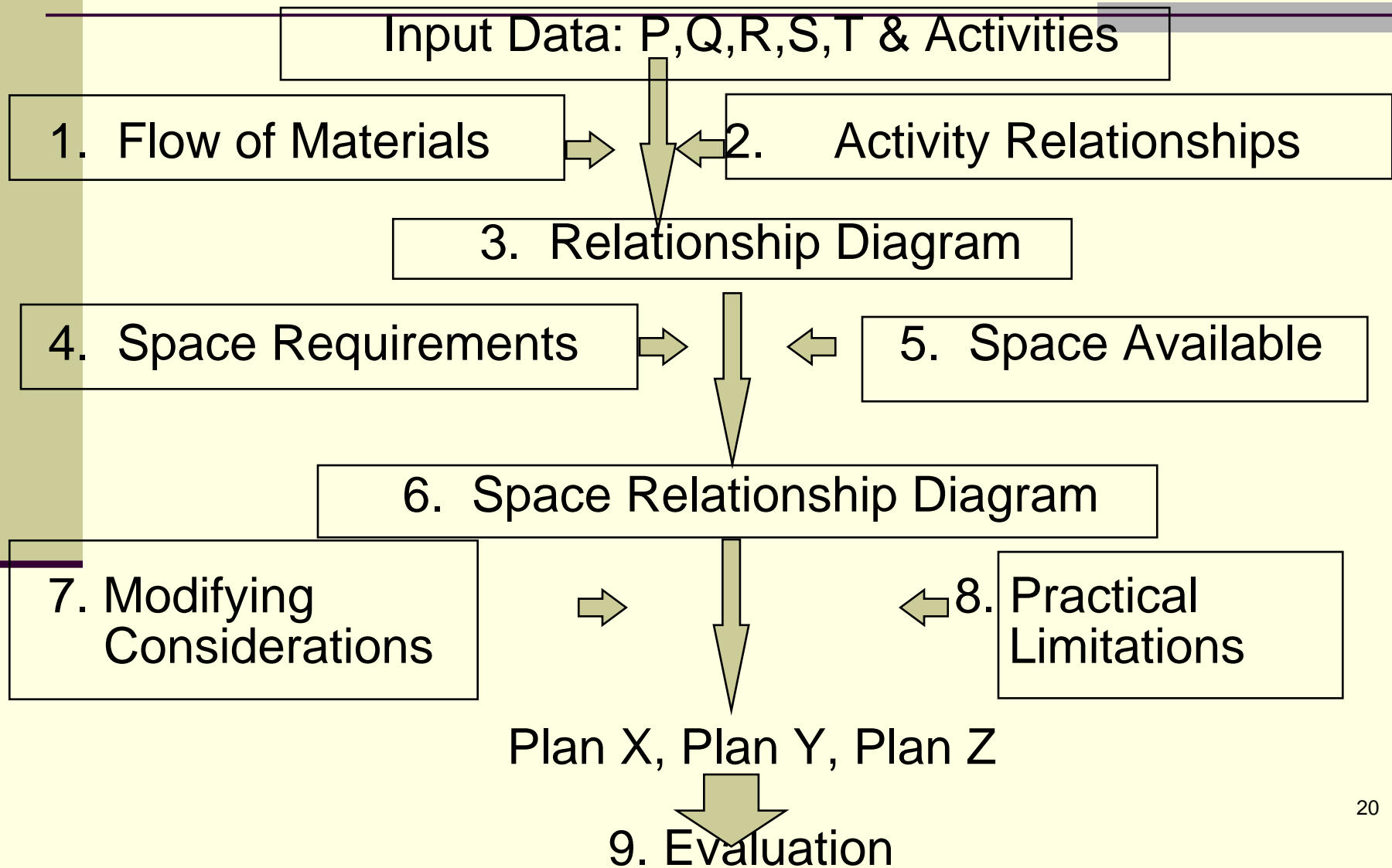

...Section V...

5.6 CRAFT-m outputs & block diagrams

	1	2	3	4	5	6	7	8	9	10	11	12	13	14	15	16	17	18	19	20	21	23	24	25
1	1	1	1	1	1	11	11	11	11	10	10	10	10	10	10	9	9	9	9	9	9	9	9	9
2	1	1	1	1	1	11	11	11	11	10	10	10	10	10	10	9	9	9	9	9	9	9	9	9
3	1	1	1	1	1	11	11	11	11	10	10	10	10	10	10	9	9	9	9	9	9	9	9	9
4	1	1	1	1	1	11	11	11	11	10	10	10	10	10	10	9	9	9	9	9	9	9	9	9
5	1	1	1	1	1	11	11	11	11	10	10	10	10	10	10	9	9	9	9	9	9	9	9	9
6	1	1	1	1	1	11	11	11	11	10	10	10	10	10	10	9	9	9	9	9	9	9	9	9
7	1	1	1	1	4	4	4	4	5	5	5	5	12	12	12	12	12	12	12	12	12	12	12	12
8	1	1	1	1	4	4	4	4	5	5	5	5	8	8	8	8	8	8	8	8	8	8	8	8
9	1	1	1	1	4	4	4	4	5	5	5	5	8	8	8	8	8	8	8	8	8	8	8	8
10	1	1	1	1	4	4	4	4	5	5	5	5	8	8	8	8	8	8	8	8	8	8	8	8
11	1	1	1	1	4	4	4	4	5	5	5	5	5	5	5	5	5	5	5	5	5	5	5	7
12	1	1	1	1	4	4	4	4	5	5	5	5	5	5	5	5	5	5	5	5	5	5	5	7
13	2	2	2	2	4	4	4	4	5	5	5	5	5	5	5	5	5	5	5	5	5	5	5	7
14	2	2	2	2	4	4	4	4	4	4	4	4	4	4	4	4	4	4	5	5	5	5	5	7
15	2	2	2	2	4	4	4	4	4	4	4	4	4	4	4	4	4	4	5	5	5	5	5	7
16	2	2	2	2	4	4	4	4	4	4	4	4	4	4	4	4	4	4	5	5	5	5	5	7
17	2	2	2	2	3	3	3	3	4	4	4	4	4	4	4	4	4	4	5	5	5	5	5	7
18	2	2	2	2	3	3	3	3	4	4	4	4	4	4	4	4	4	4	5	5	5	5	5	6
19	2	2	2	2	3	3	3	3	4	4	4	4	4	4	4	4	4	4	5	5	5	5	5	6
20	2	2	2	2	3	3	3	3	4	4	4	4	4	4	4	4	4	4	5	5	5	5	5	6
21	2	2	2	2	3	3	3	3	4	4	4	4	4	4	4	4	4	4	5	5	5	5	5	6
22	2	2	2	2	3	3	3	3	4	4	4	4	4	4	4	4	4	4	4	4	4	4	4	4
23	2	2	2	2	3	3	3	3	4	4	4	4	4	4	4	4	4	4	4	4	4	4	4	4
24	2	2	2	2	3	3	3	3	4	4	4	4	4	4	4	4	4	4	4	4	4	4	4	4
25	2	2	2	2	3	3	3	3	4	4	4	4	4	4	4	4	4	4	4	4	4	4	4	4

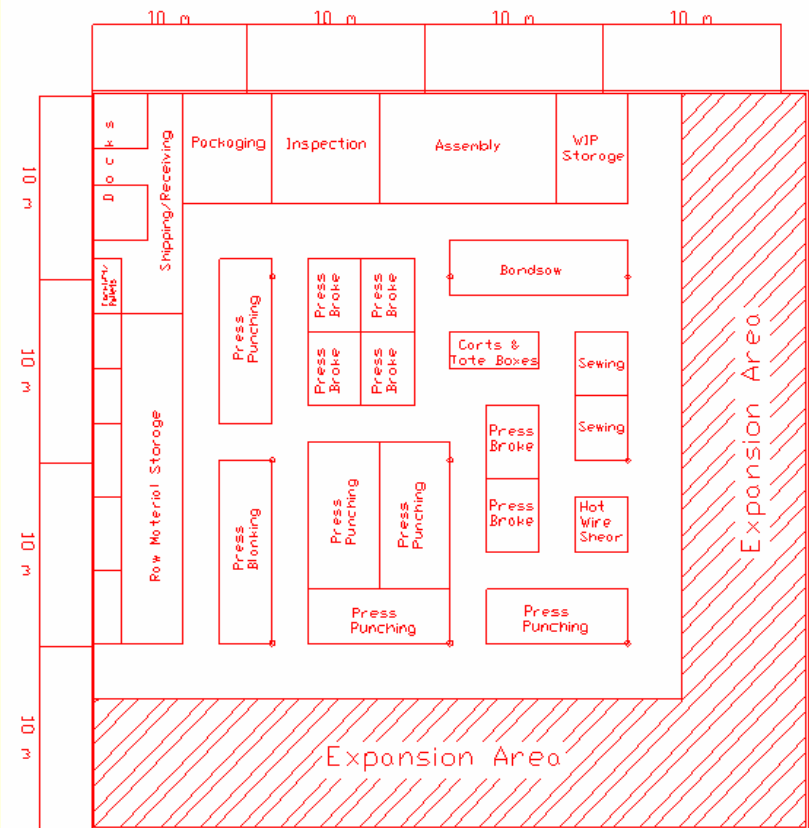

...Section V...

5.7 Layout Planning Charts

A detailed description of the sequence of operations (largely based on route sheets) for each part to aid layout planning process.

- Assembly no., material, production quantities and lot sizes.
- Part routing, machine requirements, manpower requirements, and material handling requirements

Section VI

6.1 Unit Costs

- Annual personnel costs (& benefits).
- Annual non-personnel costs.
- Add indirect costs not yet included.
- Total annual costs.
- Cost per unit.
- Selling Price (includes profit).
- Is this price **competitive?**



..Section VI...

6.2 Layout evaluation and selection

6.3 Detailed workstation drawing

- general idea of how the workstations will be laid out

6.4 Site plan

- Taking care of logistic requirements

6.5 Expansion plan

- Identification of bottleneck machines
- Impact on layout for projected growth

6.6 Plant summary

..Section VI...

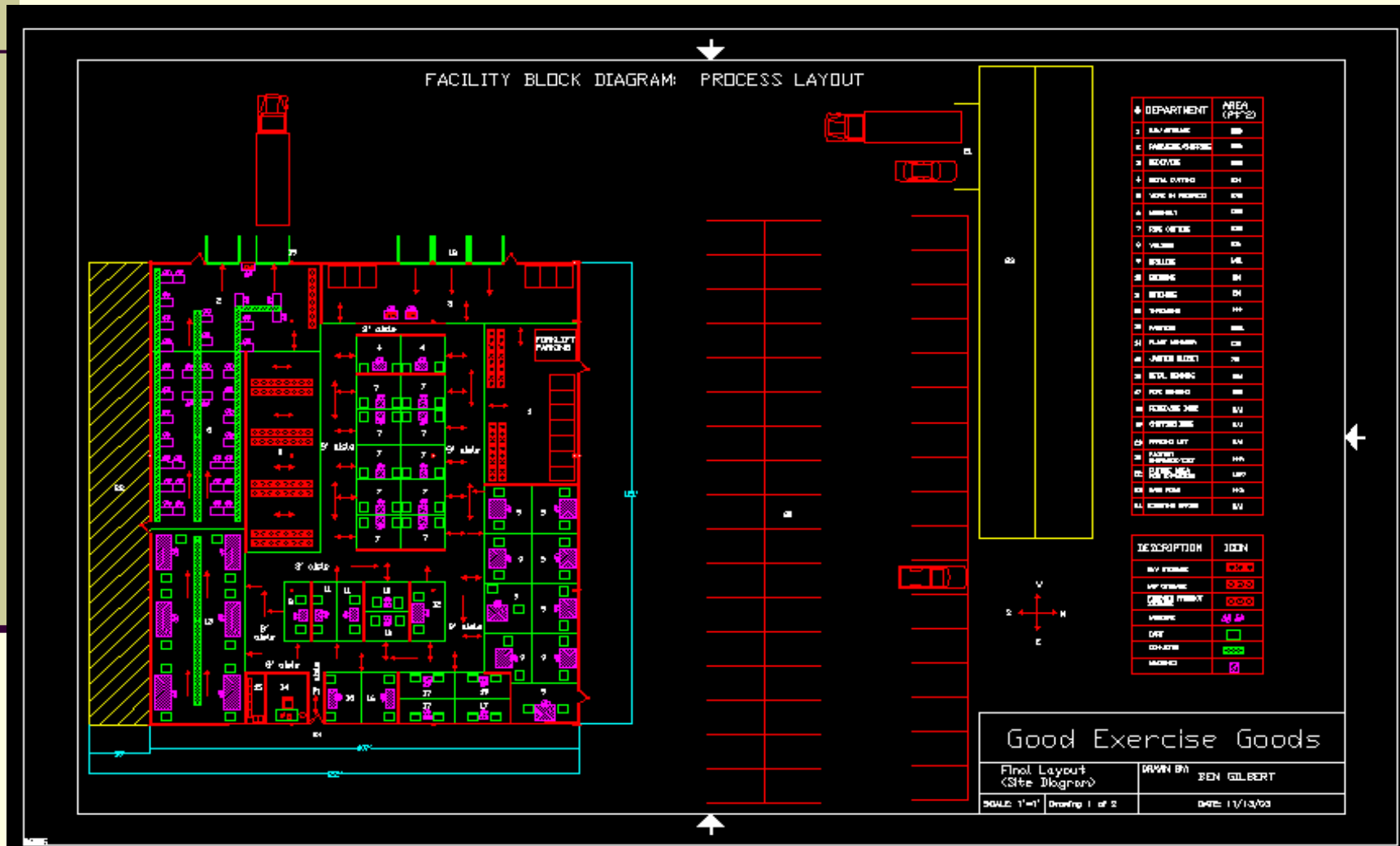

Summary of DESIGN Process

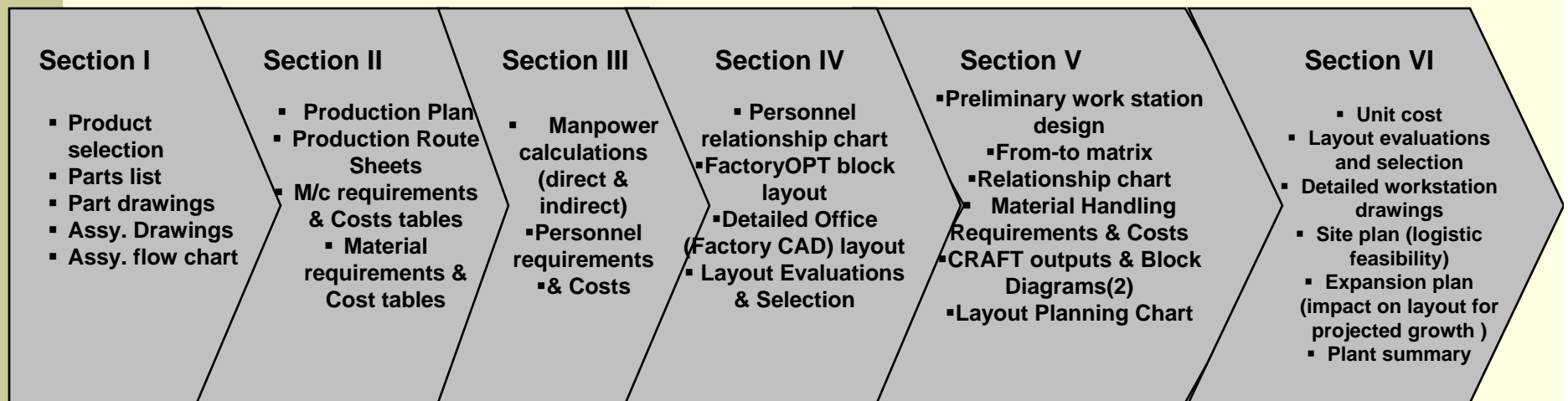

Team Deliverables..

- **Report 1 (Sections I & II) due on Oct 5 & 7**
- **Report 2 (Section III & IV) due on Nov 2 & 4**
- **Final report (Sections I - VI) due on Dec 7**
- **Presentations on Nov 30 and Dec 2**

Report Format Suggestions...

- **Cover Page** - With product name, team members, team number.
- **Table of Contents** - With page numbers.
- **Executive Summary** - One page or less. Brief description of problem(s), approach, main findings and recommendations.
- **Introduction** - Include an overview of the problem and operations. Briefly discuss the project thrust.
- **Problem Statement** - Concise description of problem(s) that are addressed by this section. What is wrong? Who is being affected? Etc.
- **Approach and Methodology** - This can have sub-sections. Justify your approach. What other approaches were available to you? This section should contain a references to the source of information cited from your reference list. Describe how you approached the problem - methods and procedures, assumptions, analysis techniques used, data sources. Why did you choose your approach?

Report Format Suggestions

- **Results** - Provide a summary of numeric and qualitative results. Discussion of results and their sensitivity to changes in assumptions. Some graphs and charts would be good in this section. Detailed printouts or calculations should be put in an appendix. Note, all pertinent information must appear within the body of the report. The reader should only need to refer to the appendices to get more detailed information.
- **Recommendations and Implementation** - Describe a clear list and discussion of your short-term and long-term recommendations. Follow this with an implementation plan. Discuss benefits for implementing your recommendations, as well as any limitations.
- **Conclusions and Acknowledgments.**

Conclusions and Questions

